

MAGNETIC LEVITATION TRANSPORTATION SYSTEM

Prachita Mane¹, Prof. Trupti Mane², Kanchan Shinde, KomalVarpe, Snehal Gaikwad
Instrumentation Department, Mumbai University
Vidyavardhini's campus, K. T. Marg, Vasai Road [W], Thane
pmane576@gmail.com¹, tpmene@rediffmail.com²

Abstract

This paper involves the design and hardware implementation of control system required for “Magnetic levitation of transportation system.”The maglev transportation system is more stable for levitation of vehicle by utilizing lead compensator.It is found that the designed system can suspend the medium of 250gms of object at a distance of about 10mm below the magnet surface while taking 1.2A of current through the magnets. Maglev systems are currently in use for applications such as bearings, high-speed trains, and manufacturing. With a streamlining of the high-precision maglev system, many unanticipated applications will develop for the future.

Keywords: Levitation, electromagnets, magnetization, Hall Effect, lead compensator.

I. INTRODUCTION

Magnetic levitation has evolved into an important consideration in designing systems requiring low losses due to friction and low energy consumption. Applications range from high-speed rail transportation systems to various industrial applications (e.g., magnetic bearings). Magnetism and closed-loop control system are the secrets to making an object float in mid-air. Magnetically-levitating (“maglev”) train technology is a high-speed transportation solution capable of contributing to pollution reduction and energy efficiency. It utilizes a linear synchronous motor for propulsion and permanent magnets for stabilization and levitation. The train can remain suspended above the ground by maintaining a constant air gap between the magnets and the rail above. The propulsion of the proposed EMS(Electro-magnetic suspension) system can be achieved by integrating the functioning linear synchronous motor.

II. PRINCIPLE OF MAGNETIC LEVITATION

Fig.1) shows the basic control system setup of the magnetic levitation system. Its magnetic field creates an upward attractive force on any magnetic object placed below.

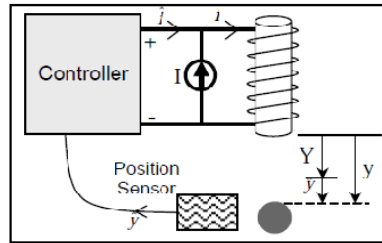

Fig.1) Basic setup of magnetic levitation

A position sensor detects the vertical position of the object and passes this information to the controller. The controller then adjusts the current to the electromagnet actuator based on the object position to create a stable levitation.

III. BLOCK DIAGRAM

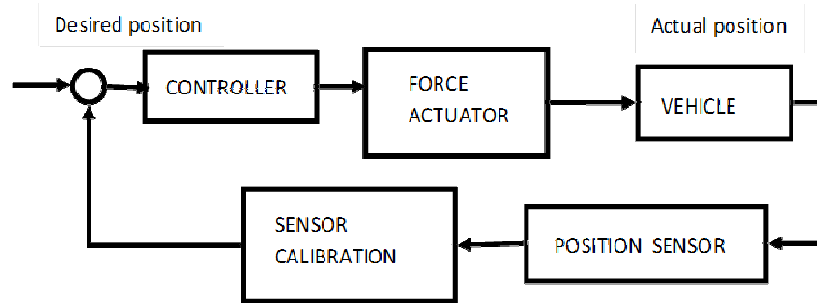

Fig.2 Block diagram

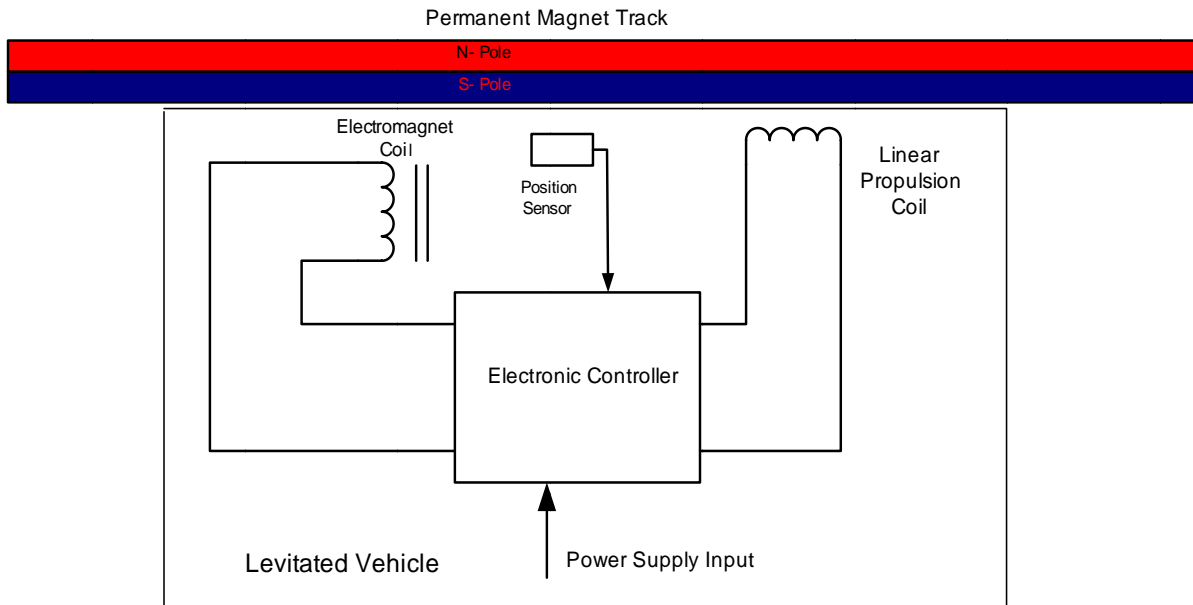

Fig.3 Detailed block diagram

Fig.3) shows the block diagram of the proposed system there are two systems involved in this project namely Levitation and Linear propulsion. Any object placed in space has tendency to attract towards earth because of gravitational force this can be counteracted by simply controlling current flowing through an electromagnet which in turn controls the generated magnetic force.

This phenomenon is called as “**magnetic levitation**”. Levitation is achieved by controlling the current in the electromagnet based on the feedback of position sensor. According to the literature we can levitate the object more than 1mm with respect to track.

“**Propulsion**” means to push forward or drive an object forward. Linear propulsion is provided by the linear propulsion coil which will be made of copper wire. The principle of linear propulsion is based on Fleming’s left hand rule. By controlling the current in the coil we can control the speed of the vehicle. The direction of motion is controlled by controlling the current direction in the linear propulsion coil.

IV. PROJECT MODEL

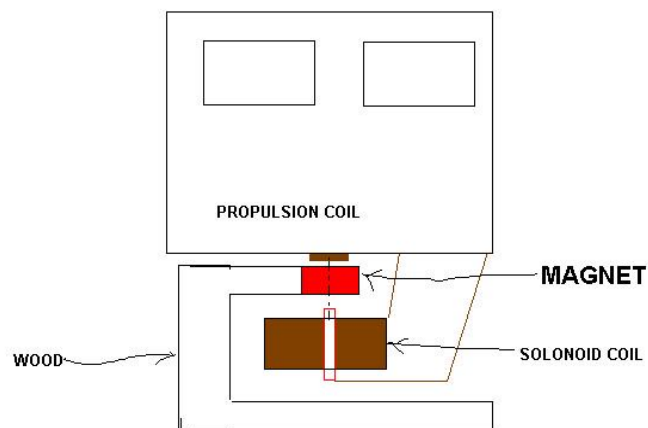

Fig 4 General Arrangement of Magnetic levitation transportation system

Fig 4) shows the general arrangement of our Project Model as shown levitation electromagnets (Solenoid coil) will be suspended below the track so as to stabilize the system from other disturbances. Track consists of Permanent magnets. Linear motion will be provided by the linear propulsion coil. All other support will be made of wood or any other light weight material which is easy to fabricate.

V. COMPONENT REQUIREMENT

A. Permanent magnet

The track of the maglev train is made up of permanent magnet array which creates attractive magnetic force to lift the train and hold it in place. There are four classes of permanent magnets:

- Neodymium Iron Boron (NdFeB or NIB)

- Samarium Cobalt (SmCo)
- Alnico
- Ceramic or Ferrite

In our project NdFeB (neodymium) type of permanent magnet is used because they have higher energy density means high magnetism.



Fig.5 Permanent Magnet

B. Electromagnets

An electromagnetic coil (or simply a "coil") is formed when a conductor (usually an insulated solid copper wire) is wound around a core or form to create an inductor or electromagnet. In maglev systems, an electromagnet is used as a moving object (train) which is attracted by a permanent magnet track. By controlling the current through the electromagnet, the position of the train is controlled.

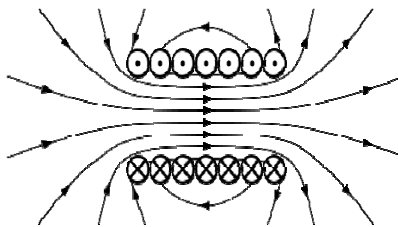

Fig.6 working principle of electromagnet

$$\text{---} = \text{---}$$

Where,

F is the force in newton

B is the magnetic field in tesla A is the area of the pole faces in square meter

μ_0 is the permeability of free space

In the case of free space (air), $\mu_0 = 4\pi \times 10^{-7} \text{ HM}^{-1}$

C. Position Sensor

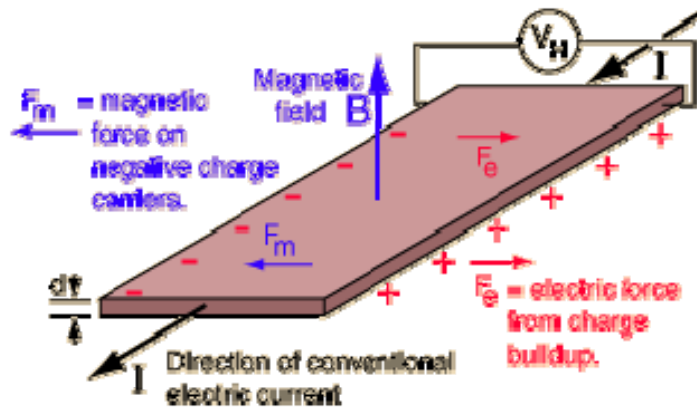

Fig.7 The Principle of Hall Effect

A Hall effect sensor is a transducer that varies its output voltage in response to a magnetic field. It is used in maglev system as a position sensor.

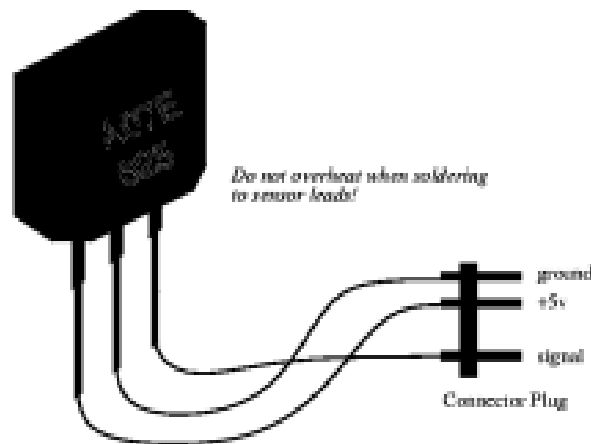

Fig.8 Hall sensor

VI. MATHEMATICAL MODELLING OF SYSTEM

The mathematical model of the project is built by writing appropriate differential equations in accordance to the typical mechanical and electrical principles of the components.

The following four equations describe the system.

1) Force actuator model:

$$F(s) = 3C \left(\frac{I_0}{Y_0^4}\right) - C \left(\frac{1}{Y_0^3}\right) I(s) \dots\dots\dots(1)$$

$$V_m(s) = RI(s) + L_1sI(s) \dots\dots\dots(2)$$

2) Electromagnet equation:

$$Y(s) = \frac{1}{Ms^2} F(s) \dots\dots\dots(3)$$

3) Sensor equation:

$$V(s) = aY(s) \dots\dots\dots(4)$$

From these equations transfer function of the system is found. The transfer function of the system is the ratio of the position of vehicle below the magnet Y(s) to the current through the magnet I(s).

Hence,
$$G(s) = \frac{Y(s)}{I(s)}$$

It can be expressed as,

$$G(s) = \frac{V_s(s)}{V_m(s)}$$

So, System transfer function:

$$G(s) = \frac{Vs(s)}{Vm(s)} = -C \frac{\frac{a}{Y_0} \frac{b}{Y_0^2}}{\frac{MY_0^3 L_1}{\left[\left(s + \frac{R}{L_1}\right) \left(s^2 - \frac{3CI_0}{MY_0^4}\right) \right]}}$$

Following parameters are the constant of the magnet, the resistance and the inductance of the magnetic coil, the gain of the sensor and the steady-state current and the equilibrium position of a given mass of vehicle. The parameters obtained are given in table (1)

Table (1) Parameters for magnetic levitation system

Parameters	Abbreviations	Value
Equilibrium distance	Y ₀	10e ⁻³
Equilibrium current	I ₀	1.2
Mass of the object	M	250g
Force constant	C	0.3
Coil resistance	R	3.3Ω

Coil inductance	L_1	$2.5e^{-3}$
Sensor gain	a	3.80
	b	0.115

From the above values transfer function is obtained as

$$G(s) = \frac{2.518e006}{s^3 + 1320s^2 - 2943s - 3.885e006}$$

For above transfer function root locus is drawn using MATLAB.

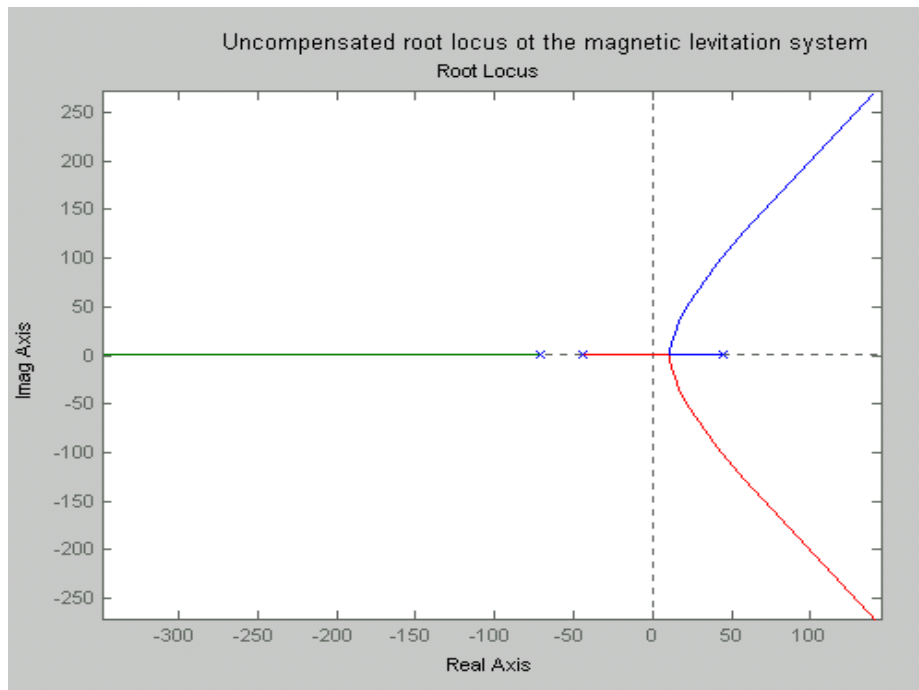

Fig. 9) Uncompensated root locus

The above root locus indicates that desired performance cannot be achieved just by adjusting the system gain. So it is necessary to reshape the root locus to meet the desired specifications by inserting lead compensator. Lead compensation equation is

$$D(s) = k \frac{s+30}{s+300}$$

Now, selecting the value of gain $k=46$ we get compensated root locus as,

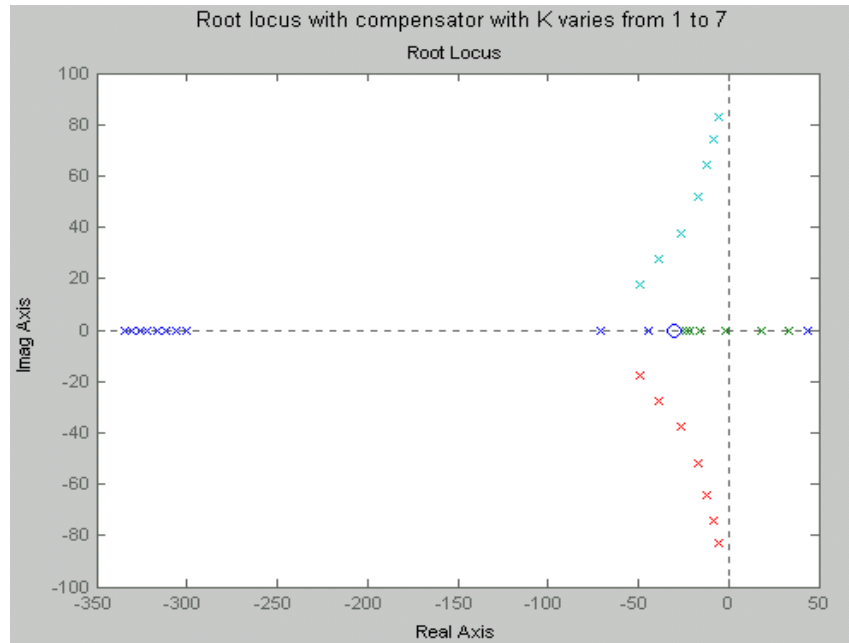

Fig.10) compensated root locus

From the circuit diagram shown in figure R1, R2 and C form the compensator network where as R3 and R4 form the compensator gain (K). The transfer function between R1, R2 and C is ratio of the input voltage to the controller V1 to the output voltage V2.

$$\frac{V_2}{V_1} = \frac{(R_1 s C + 1)}{R_2 (R_1 s C + 1) + R_1}$$

$$\frac{V_2}{V_1} = \frac{s + R_2}{R_1 R_2 C} \frac{R_1 R_2 C}{s + R_1 + R_2}$$

By carefully selecting R1=330KΩ and C = 0.1μF, R2 is calculated to be 37KΩ. While carry out this calculation it is important to avoid cancellation between numerator and denominator because some of the terms will disappear.

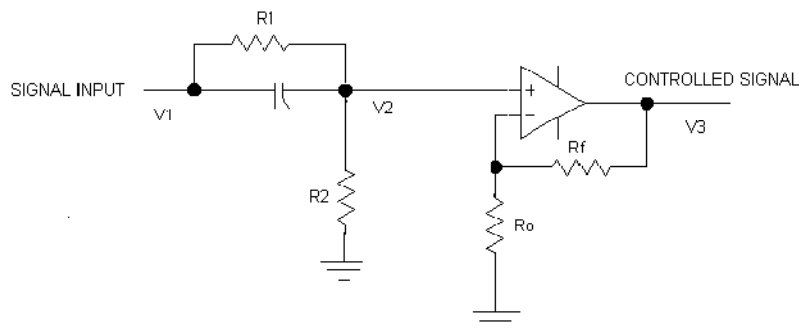

Fig.11) lead compensator

The constant gain K is selected 46 from the root locus. Therefore the compensator above will be used in providing the gain; this is given by

$$K = 1 + R_f / R_0 = 46$$

$$R_f = 45 * R_0$$

$$R_0 = 10K\Omega$$

$$R_f = 45 K\Omega$$

VII. CONCLUSION

This magnetic levitation system is found to be unstable, because of the system nonlinearity. So the system is linearized about an operating point and is implemented using analog controller (Lead Compensator). The propulsion system can be developed that forces a levitating electromagnet (vehicle) to slide along a series of permanent magnets through the use of alternating magnetic fields. This project demonstrates the feasibility of magnetic levitation for number of diverse applications. This type of actuation can be used in harsh environments (corrosive, vacuum, etc.) where traditional mechanical or hydraulic actuators might not survive.

VIII. ACKNOWLEDGEMENT

We would like to thank “Department of Instrumentation, Vidyavardhini’s College of Engineering, Vasai” for supporting and providing all the required facilities.

REFERENCE

1. “Design and implementation of a phase lead compensator for magnetic levitation” by Dahiru Sani Shu’aibu and Sanusi Sani Adamu, Bayero University, Kano, Nigeria
2. Mukherji B.N “practical op-amp project” BPB publications Delhi Madras Hyderabad, 1980.
3. Theraja B.L. (1998), “A text book of Electrical Technology” S.CHAND & Company Ltd, Ram Nagar, New Delhi.
4. Lundberg, K. H., Lilienkamp, K. A., Marsden, G., Low-Cost Magnetic Levitation Project Kits, IEEE Control Magazine, Oct. 2004, p.65-69
5. “Design, development and testing of an electromagnet for magnetic levitation system” by Dahirusanishu’aibu and Sansuisaniadamu, Department of Electrical Engineering, Bayero University, Kano, Nigeria

6. "Design of a small scale prototype for a stabilized permanent magnet levitated vehicle" By Geoffrey A. Long, O. James Fiske, Brad E. Paden, launch point technologies, Goleta, California, USA
7. Development of a real-time digital control system with a hardware-in-the-loop magnetic levitation device for reinforcement of control education Shiakolas, P.S.; Piyabongkarn, D. Education, IEEE Transactions on Volume 46, Issue 1, Feb 2003 Page(s): 79-87 [Digital Object Identifier 10.1109/TE.2002.808268](#)
8. Real-time adaptive control using neural generalized predictive control Haley, P.; Soloway, D.; Gold, B. American Control Conference, 1999. Proceedings of the 1999 Volume 6, Issue , 1999 Page(s): 4278 - 4282 vol.6 [Digital Object Identifier 10.1109/ACC.1999.786371](#)
9. On the development of a real-time digital control system using x PC-Target and a magnetic levitation device Shiakolas, P.S.; Piyabongkarn, D. Decision and Control, 2001. Proceedings of the 40th IEEE Conference on Volume 2, Issue , 2001 Page(s): 1348 - 1353 vol.2 [Digital Object Identifier 10.1109/2001.981077](#).
10. Review of Maglev Train Technologies Hyung-Woo Lee¹, Ki-Chan Kim², and Ju Lee² Korea Railroad Research Institute, Uiwang 437-757, Korea Department of Electrical Engineering, Hanyang University, Seoul 133-791, Korea